

Evaluation Board Instruction Manual

ADC10321

10-Bit, 20MSPS, 98mW Analog-to-Digital Converter

ADC10221

10-Bit, 15MSPS, 98mW Analog-to-Digital Converter

ADC10030

10-Bit, 30MSPS, 125mW Analog-to-Digital Converter

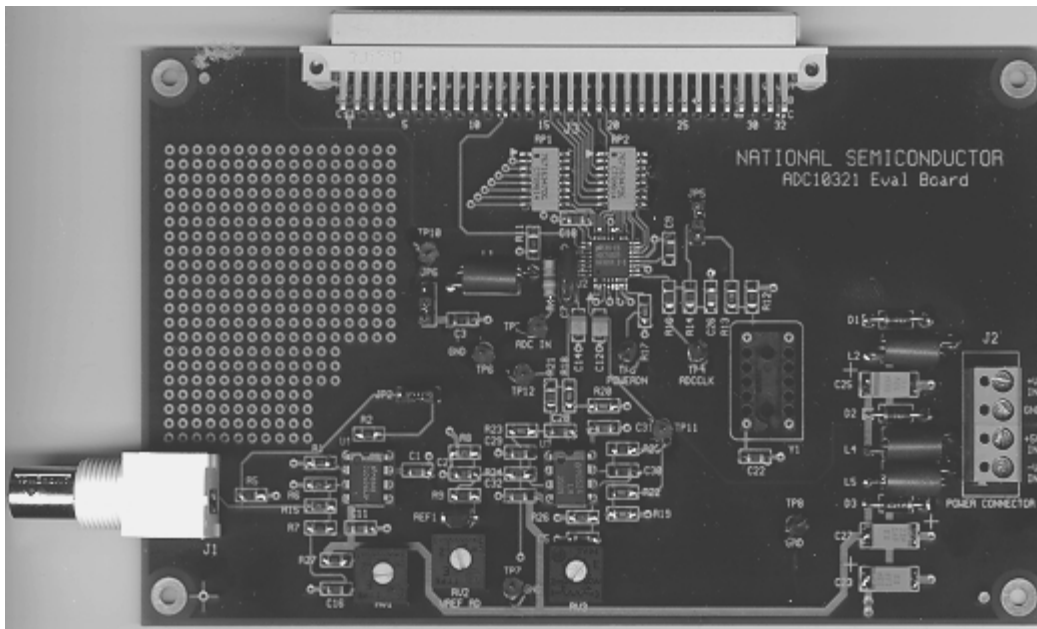

This page intentionally left blank.

1.0 Introduction.....	4
2.0 Board Assembly.....	4
3.0 Quick Start.....	4
4.0 Functional Description.....	5
4.1 Input (signal conditioning) circuitry.....	5
4.2 ADC reference circuitry.....	5
4.3 Board Outputs.....	5
4.4 Power requirements.....	5
5.0 Installing the ADC10321 Evaluation Board.....	5
6.0 Evaluation Board Specifications.....	5
7.0 Hardware Schematic.....	6
8.0 Evaluation Board Bill of Materials.....	7
APPENDIX.....	8
A1.0 Operating in the Computer (Automatic) Mode.....	8
A2.0 The Logic Evaluation Board and WaveVision™ Software.....	8
A3.0 Exploring the Video Waveform.....	8
A3.1.1 Estimating Differential Gain.....	8
A3.1.2 Looking at Frequency Response.....	9
A3.1.3 Low Frequency Triangle Wave Input.....	9
A3.1.3.1 Monotonicity and Uncertainty.....	9
A3.1.3.2 Rising / Falling Symmetry.....	9
A3.2 The FFT Plot.....	10
A3.2.1 Dynamic Performance Estimates.....	10
A3.2.2 Bandwidth Estimation.....	10
A4.0 Saving and Retrieving Files.....	10
A4.1 Binary Files.....	10
A4.2 ASCII Files.....	10

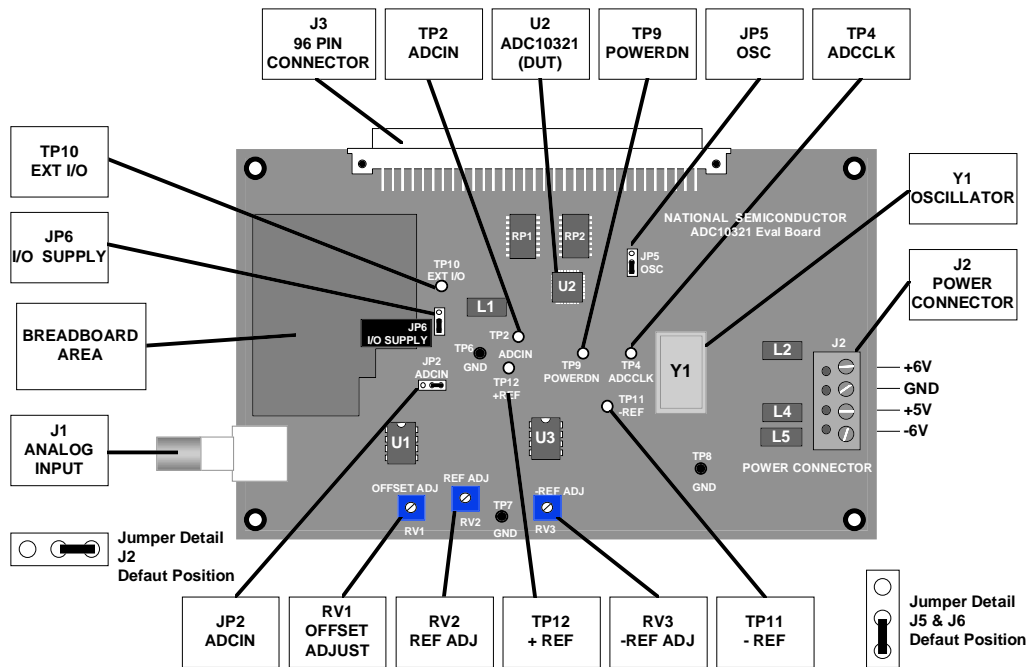

Figure 1. Component Locations. Jumpers are shown in default positions

1.0 Introduction

The ADC10321EVAL Evaluation Board (consisting of the ADC10321 Evaluation Board and this manual) is designed to ease evaluation and design-in of National Semiconductor's ADC10321 20 Msps Analog-to-Digital Converter, ADC10221 15 Msps Analog-to-Digital Converter and the ADC10030 30Msps Analog-to-Digital Converter. When the ADC10321 is mentioned, the ADC10221 and the ADC10030 are understood to also be indicated.

The evaluation board can be used in either of two modes. The first mode is the Manual or Stand Alone mode where the board can be used with suitable test equipment to evaluate the ADC10321's performance.

The second mode is the Computer or Automatic mode. In this mode, the ADC10321 Evaluation Board is connected to the WaveVision™ Digital Interface Board (order number WAVEVISION BRD), which is connected to a personal computer using a serial communications port. Thus, evaluation is simplified with National Semiconductor's WaveVision™ software, designed for Microsoft Windows 3.1 or later. The external clock capability should NOT be used in this mode

The signal at BNC connector J1 (the Analog Input to the board) is digitized and is available at 96-pin DIN connector J3.

Provision is made for adjustment of offset voltage. Some adjustment of gain is possible through adjustment of the reference voltages.

2.0 Board Assembly

The ADC10321 Evaluation Board can come as a bare board with a surface mounted ADC10321 and must be assembled, or can be purchased as a fully assembled board. Refer to Figure 1 for the location of major components, to Bill of Materials (Section 8.0) for component description and part types and to Figure 2 for the Evaluation Board schematic.

While the oscillator (Y1) may be soldered to the board, using a socket will allow you to change frequencies and to remove this oscillator when using the board with the Digital Interface Board. The oscillator should not be used when the board is used in conjunction with the Digital Interface Board in the Computer or Automatic mode.

The breadboard area is useful for building customized circuitry. For best performance, keep circuitry neat and arrange components to provide short, direct connections, especially in the signal path.

3.0 Quick Start

Once the board is assembled, the following will allow you to get the board up and running quickly. The digitized signal is available at pins B16 through B20 and C16 through C20 of J3. See the Evaluation Board schematic of Figure 2 for details.

1. Be sure that all jumpers are in their default positions, as shown in Figure 1.
2. Be sure there is a 15MHz, 20MHz or 30MHz oscillator in its socket, depending upon the ADC being evaluated.
3. Connect +6V, GND, +5V and -6V to Power Connector J2.
4. Adjust RV2, +Ref Adjust, for 3.5V at TP12.
5. Adjust RV3, -Ref Adjust, for 1.5V at TP11.
6. Adjust RV1, DC Offset, for 2.5VDC at TP2.
7. Connect a 1MHz to 9MHz signal from a 75-Ohm source to Analog Input BNC J1. Adjust the amplitude for 2V_{p-p} at TP2.
8. Readjust RV1 and the input signal amplitude as needed to ensure that the signal at TP2 remains within the limits of the top and bottom reference voltages at TP12 and TP11, respectively.

4.0 Functional Description

Figure 1 shows the block diagram of the ADC10321 evaluation board. U2 is the device under test. This board supports the ADC10221, ADC10321 and the ADC10030 Analog-to-Digital Converters.

4.1 Input (signal conditioning) circuitry.

The input signal to be digitized should be applied to BNC connector J1. This 75 Ohm input is intended to accept any signal input, including composite video, with amplitudes from 0.5V to 1V peak-to-peak.

The input circuit using U1 (an CLC409) provides a gain of approximately +2.67. An adjustable offset of 0V to 1V is controlled by RV1. This can be used to ensure that the signal remains between the top and bottom reference voltages of the ADC10321.

4.2 ADC reference circuitry.

The reference voltages are adjustable through RV2 and RV3. RV2 adjusts the +REF, or top voltage reference. RV3 adjusts the -REF, or bottom reference voltage. Recommended top and bottom reference voltages are 3.5VDC and 1.5VDC respectively.

If the difference between the top and bottom reference voltages is small, or if the input signal does not use all or nearly all of the ADC10321 input dynamic range, you could see a degradation of SNR because the quantization noise becomes a larger percentage of the input signal. We recommend operating the ADC10321 with a difference of 1.5V to 2V between the top and bottom references, and driving the ADC10321 analog input with a peak-to-peak voltage at TP2 of 95% to 98% of the difference between the top and bottom reference voltages found at TP12 and TP11, respectively.

Because the bottom reference voltage is derived from the top reference voltage, the top reference voltage should be set before adjusting the bottom reference voltage.

4.3 Board Outputs.

The digital data from the ADC10321 output, as well as a clock signal for this data, is available at the 96 pin DIN Connector J3 (See Figure 2). Resistors RP1 and RP2 are used to isolate from any circuits or instruments that the ADC10321 drives, helping to reduce the digital noise that gets back into the analog input.

4.4 Power requirements.

Power to this board is supplied through power connector J2 at the right side of the board. Voltage and current requirements are:

- +5V at 50mA (1.0A with the Digital Interface Board)
- +6V at 20mA
- -6V at 20 mA.

The power supplies are protected with shunt diodes.

Power for the ADC10321 can come from the +5V applied to Power Input Connector J2, or from an external +5V supply applied to TP10. Selection of the ADC10321 supply source is done with Jumper JP6. See Figure 1.

5.0 Installing the ADC10321 Evaluation Board

The evaluation board requires power supplies as described in paragraph 4.4. No input signals for evaluation are generated on the board. An appropriate signal generator (such as the HP3325B, HP8662A or the Tektronix TSG130A) with 75-Ohm source impedance should be connected to the Analog Input BNC, J1. If the signal is not of a single frequency with very low harmonic content, use a bandpass or lowpass filter to reduce harmonic information if performing an FFT to evaluate dynamic performance.

If this board is used in conjunction with the Digital Interface Board and WaveVision™ software, a cable with a DB-9 connector should be connected between the Digital Interface Board and the host computer. See the Digital Interface Board manual for details.

If the board is used in the Computer or Automatic mode, the converter can be evaluated at various clock rates with the selection of the appropriate crystal on the Digital Interface Board and selection of the correct DIP switch setting. See the Digital Interface Board manual for details.

6.0 Evaluation Board Specifications

Board Size:	3.5" x 6.3" (8.9 x 16 cm)
Power Requirements:	+5V @ 50 mA *
	+6V @ 20 mA
	-6V @ 20 mA
Clock Frequency Range:	1 MHz to 20 MHz
Analog Input	
Nominal Voltage:	1V _{p-p}
Impedance:	75 Ohms
Normal board Input Range:	0.5V _{p-p} to 1.0V _{p-p}

* +5V supply must supply 1.0 Amp when this demo board is used with the Digital Interface board.

7.0 Hardware Schematic

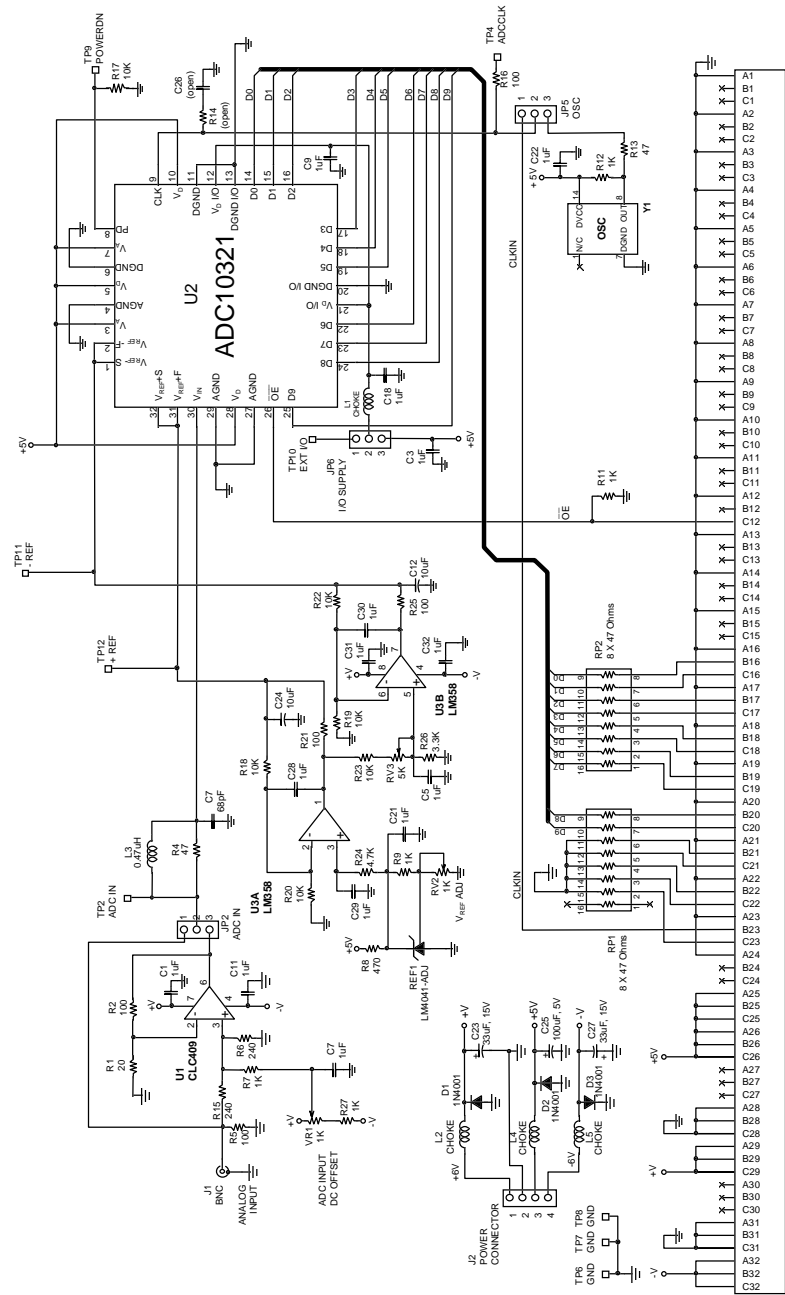

Figure 2. Eval Board Schematic

8.0 Evaluation Board Bill of Materials

C1, C3, C5, C9, C11, C16, C18, C21, C22, C28, C29, C30, C31, C32,	1uF	Type 0805
C7	68pF	Mica Type
C12, C14, C24	10uF, 6V	Type 3216 (A size)
C23, C27	33uF, 15V	Type 7343 (D size)
C25	100uF, 6V	Type 7343 (D size)
C26	NOT USED	
D1, D2, D3	1N4001	Various
J1	BNC	DigiKey # ARF1177-ND
J2	2-Post Terminal Block (2 needed)	DigiKey # ED1605-ND
J3	96 Pin Female DIN Connector	DigiKey # H7096-ND
JP2, JP5, JP6	3-PIN Post Header	DigiKey # A19351-ND
--	Shorting Jumper (3 needed)	DigiKey # S96001-ND
L1,L2, L4, L5	Choke	DigiKey # M2204-ND
L3	0.47uH	DigiKey # M7809-ND
R1	20	Type 0805
R2, R5, R16, R21, R25	100	Type 0805
R4, R13	47	Type 0805
R6, R15	240	Type 0805
R7, R9, R11, R12, R27	1K	Type 0805
R8	470	Type 0805
R14	NOT USED	
R17, R18, R19, R20, R22, R23	10K	Type 0805
R24	4.7K	Type 0805
R26	3.3K	Type 0805
REF1	LM4041CIZ-ACJ	National Semiconductor
RP1, RP2	8 x 47	DigiKey # 4816P-1-470-ND
RV1, RV2	1K	DigiKey # 3386F-102-ND
RV3	5K	DigiKey # 3386F-502-ND
TP2, TP4, TP6, TP7, TP8, TP9, TP10, TP11, TP12	Breakable Header	DigiKey # S1012-36-ND
U1	CLC409AJP	National Semiconductor
U2	ADC10321CIVT	National Semiconductor
U3	LM358	National Semiconductor
Y1	20MHz Oscillator	DigiKey # CTX-119-ND
Socket	for U1, U3	8-pin DIP
Socket	for Y1	DigiKey # A462-ND

APPENDIX

WaveVision and Computer Mode Operation with the Digital Interface Board

A1.0 Operating in the Computer (Automatic) Mode

When using the ADC10321 evaluation board with the Digital Interface Board for Computer mode operation, you should short pins 1 and 2 of Jumper JP5 on the ADC10321 evaluation board. This connects the clock oscillator from the Digital Interface Board to the ADC10321's clock input pin. It is also a good idea to remove the oscillator from the ADC10321 eval board for Computer mode operation to prevent noise problems.

Follow these steps to operate the board in the Computer mode. Refer to Figure 1.

1. Set up the Digital Interface Board per the instructions in the Digital Interface Board manual.
2. Adjust trim pots. RV1, RV2, and RV3 as indicated in Quick Start Section 3.0.
3. Use WaveVision™ to set up the board per the Digital Interface Board Manual. Remember that the clock frequency on the board is set by Program Switch of the Digital Interface Board. See the Digital Interface Board manual for more information. The external clock option should NOT be used in the Computer mode.
4. Select the desired number of samples to acquire, then acquire the data (ALT, E, B or CTRL-B; see the Digital Interface Board manual).

Once data transfer is complete, portions of the waveform may be selected for viewing by clicking the mouse pointer at one corner of the area to be viewed and dragging to the opposite corner. Restore the full display by right clicking over the display.

If desired, an FFT may be performed on the captured data (ALT, E, F or CTRL-F or click on FFT icon. See Appendix of the Digital Interface Board manual).

A2.0 The Logic Evaluation Board and WaveVision™ Software

To fully evaluate the ADC10321 with minimal external equipment, you need the WaveVision™ Evaluation Kit (order number WAVEVISION BRD). This kit consists of a Digital Interface Board that connects to the ADC10321 Evaluation board through the 96-pin DIN connector and a 3.5" program diskette with all the software needed to control the combined Digital Interface Board and ADC10321 Evaluation board.

A3.0 Exploring the Video Waveform

WaveVision™ software and the ADC10321 Evaluation Board add a new tool to the video designer's toolbox. The evaluation board, together with the Digital Interface Board, can be used to capture any signal up to and beyond 1/2 the clock rate, including video. The captured data can then be displayed and performance parameters can be measured.

See the Appendix of the Digital Interface Board manual for WaveVision™ screen drawings that show software operation.

A3.1 Basic Waveform

After the ADC10321 Evaluation Board has uploaded a captured waveform to the PC, WaveVision™ displays this waveform on the computer monitor. The WaveVision™ software can be used to evaluate the ADC10321's performance.

A3.1.1 Estimating Differential Gain

To estimate differential gain of the circuit, capture a modulated video ramp and measure the peak-to-peak amplitude of the subcarrier (3.58 MHz for NTSC, 4.43 MHz for PAL) at the white (highest) level and at the black (lowest) level. The percent difference between these two levels is an estimate of differential gain.

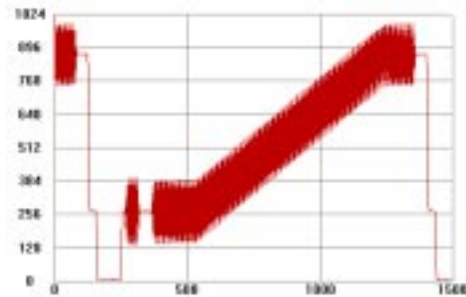

Figure 5. Modulated ramp of a video signal. The chroma level near black, subtracted from the chroma level near white will give an estimate of overall differential gain of the circuit.

Figures 6 and 7 show enlargements of the black level and the white level, respectively, of the signal in Figure 5.

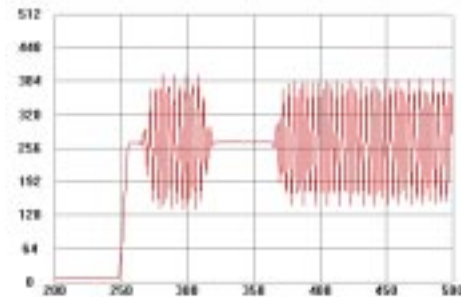

Figure 6. Enlargement of the black level area of the modulated ramp of Figure 5 showing the digital values of the chroma information.

Another method of estimating differential gain (without a modulated video ramp), is to capture a pure, stable continuous wave at two different d.c. levels. The peak-to-peak amplitude of the sine wave should be about 25% of the input full scale swing, or about 500mV_{p-p} with a 2V reference span.

First, capture the waveform with the offset adjust potentiometer, VR2, set to give an average code of about 256 at the ADC output. This would correspond to a DC potential of about 2.0V at the ADC input (TP1) with a nominal 3.5V and 1.5V at the top and bottom reference inputs, respectively. Measure the peak-to-peak level of the captured waveform.

Then capture another waveform with the offset adjust potentiometer, VR2, set to give an average code of about 768 at the ADC output. This would correspond to an input DC potential of about 3.0V at the ADC input (TP1, Figure 1 and Figure 14). Measure the peak-to-peak level of this signal. You might want to open a new window for this second waveform capture, so that both levels may be displayed at once.



Figure 7. Enlargement of the white level area of the modulated ramp to be compared with the black level. The percent difference between the two chroma levels is differential gain.

The estimated differential gain is the percentage difference in the peak-to-peak readings of these two signals.

A3.1.2 Looking at Frequency Response

A video multiburst signal can be used to evaluate system frequency response. This approach will show the overall system response, including any input signal conditioning.

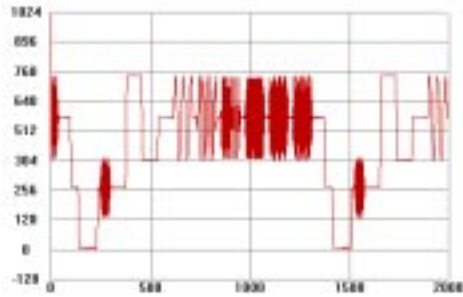

Figure 8. This multiburst signal shows the gain flatness of the overall circuit. Notice that all frequencies have about equal amplitude.

A multiburst signal has bursts of fixed frequencies, one after the other, that usually start at 0.5 MHz and increase to 4.5 MHz or 5.5 MHz, depending upon the video standard.

Figure 8 shows a captured PAL multiburst signal. Note the flat response, with all frequency components at the same amplitude.

The individual preset frequencies of the multiburst signal can be determined by performing an FFT on the data, (Figure 9). The individual frequencies are, in this case, 0.5, 1, 2, 4, 4.75 and 5.75 MHz. The dynamic data to the right of the spectrum plot is useless for such data.

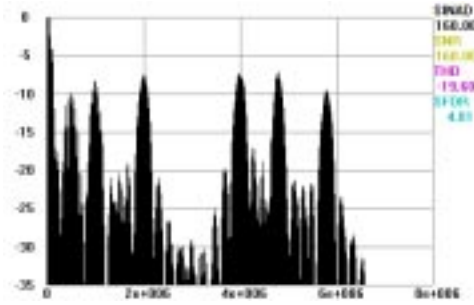

Figure 9. This FFT of the multiburst signal shows frequency on the horizontal axis, allowing a measurement of the bandwidth required for the burst of each frequency. This spectrum of the whole video signal indicates the bandwidth required to pass this signal without distortion.

A3.1.3 Low Frequency Triangle Wave Input

A low frequency (about 15KHz) triangle wave will provide general information on ADC performance.

A3.1.3.1 Monotonicity and Uncertainty

When a voltage ramp is digitized, the code sequence shows increasing codes up to the peak level, or decreasing codes to the minimum level, depending upon whether the slope of the ramp. A waveform with always increasing or decreasing codes is said to be monotonic, as in Figure 10a.

A converter that has one or more instances of codes consistently going in the wrong direction is said to be non-monotonic. See Figure 10b.

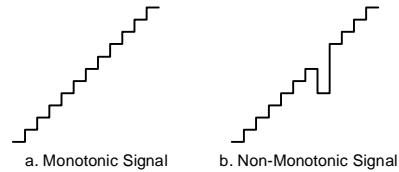

Figure 10. Monotonicity means codes are continually increasing or decreasing.

When digitizing signals with rise and fall times slow enough to result in more than one conversion result of the same code in sequence, it is normal to have some code uncertainty when the input is at a code transition point. See Figure 11.

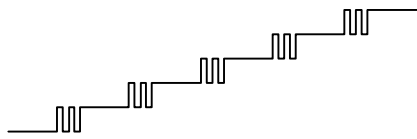

Figure 11. Code uncertainty when the ADC input voltage is near a code transition point.

A3.1.3.2 Rising / Falling Symmetry

The ideal A/D converter will give the same code when digitizing a given input voltage whether that voltage is approached from a lower voltage or from a higher voltage. If a *symmetrical* triangle wave is presented to the ADC, the falling side of the reconstructed waveform should be a mirror image of the rising side at the input and at the output. In practice, however, this usually is not the case. Looking at the WaveVision™ data display of a digitized triangle wave will show how asymmetrical the two slopes are with respect to each other. Choose your generator with care as *many triangle wave signal generators have non-symmetrical slopes*.

A3.2 The FFT Plot

At the right side of the FFT plot are dynamic performance estimates of SINAD, SNR, THD and SFDR (Spurious-Free Dynamic Range). These readings are meaningful only for a sine wave input to the ADC and are accurate only to the extent that the input waveform is stable and contains a single frequency.

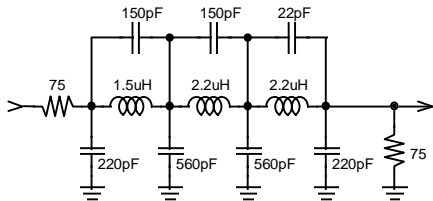

Figure 12. This 4MHz cutoff elliptic filter can be used for input frequencies of 1MHz to 4MHz. It should be driven by a generator of 75 Ohms source impedance and terminated with 75 Ohms. This termination is provided by the ADC10321 evaluation board. The input resistor shown here is normally the generator output impedance.

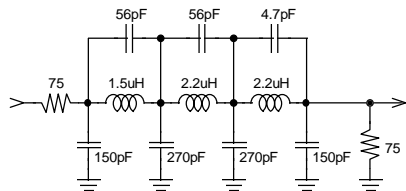

Figure 13. This elliptic filter has a cutoff frequency of about 11MHz and is suitable for input frequencies of 5MHz to 10MHz. Other comments relating to Figure 12 apply here.

Harmonics and other interfering signals at the input can be attenuated by inserting an appropriate filter at the Analog Input. The elliptic filters of Figures 12 and 13 are examples of suitable filters for input frequencies of 1MHz to 5MHz and for 5MHz to 10MHz, respectively. These filters can filter a square wave, reducing 3rd and higher harmonics to negligible levels.

The FFT plot, however, can provide information from captured signals other than single frequency sinusoids. One example is shown in Figure 9.

A3.2.1 Dynamic Performance Estimates

The dynamic performance as indicated by SINAD, SNR, THD and SFDR are estimates rather than hard and fast figures because their accuracy depends upon how much of the ADC10321's dynamic input range is used, and how many samples are taken.

For example, if the input is reduced below a full scale swing such that the maximum and minimum codes obtained at the output are 945 and 80, rather than the full scale values of 1023 and 0, only about 84% of the code range is used. The result is an apparent degradation of SNR. On the other hand, if the input exceeds the input dynamic range such that the top and bottom of the input signal is clipped at the ADC10321's output, THD, SFDR and SINAD will be degraded.

Furthermore, apparent performance may be limited by the purity of the input signal used.

A3.2.2 Bandwidth Estimation

If a constant amplitude frequency sweep is applied at the Analog Input (J2) and the signal at the ADC input is digitized and displayed, the data display will show any frequency dependent amplitude variation.

A4.0 Saving and Retrieving Files

WaveVision™ allows you to save data in two formats. One is a binary file, the other is an ASCII file. See the Digital Interface Board manual.

A4.1 Binary Files

To save a binary file for use later by WaveVision™, you can either click on the save icon, enter ALT, E, S or enter CTRL-S. You will be prompted for a file name the first time you save a given set of data. The binary file created contains information as to program settings as well as the raw data.

To retrieve a binary file in WaveVision™, you may click on the Open File icon, enter ALT, E, O or enter CTRL-O. You will be prompted for the name of the file you wish to retrieve.

A4.2 ASCII Files

To export an ASCII file for use later by another program, such as Excel, you must enter ALT, E, D. You will be prompted for a file name.

The ASCII file will contain only raw data with one data point per line.

To import an ASCII file, whether created with WaveVision™ or with any other program or utility, enter ALT, E, I. You will be prompted for the name of the file you wish to retrieve. Remember that imported files must have one data point per line and should have a binary weighted number of samples.

This page intentionally left blank.

The ADC10321 Evaluation Board is intended for product evaluation purposes only and is not intended for resale to end consumers, is not authorized for such use and is not designed for compliance with European EMC Directive 89/336/EEC.

WaveVision™ is a trademark of National Semiconductor Corporation. National does not assume any responsibility for use of any circuitry or software supplied or described. No circuit patent licenses are implied.

LIFE SUPPORT POLICY

NATIONAL'S PRODUCTS ARE NOT AUTHORIZED FOR USE AS CRITICAL COMPONENTS IN LIFE SUPPORT DEVICES OR SYSTEMS WITHOUT THE EXPRESS WRITTEN APPROVAL OF THE PRESIDENT OF NATIONAL SEMICONDUCTOR CORPORATION. As used herein:

1. Life support devices or systems are devices or systems which, (a) are intended for surgical implant into the body, or (b) support or sustain life, and whose failure to perform, when properly used in accordance with instructions for use provided in the labeling, can be reasonably expected to result in a significant injury to the user.
2. A critical component is any component in a life support device or system whose failure to perform can be reasonably expected to cause the failure of the life support device or system, or to affect its safety or effectiveness.



National Semiconductor Corporation Americas
Tel: 1-800-272-9959
Fax: 1-800-737-7018
Email: support@nsc.com

National Semiconductor Europe
Fax: +49 (0) 1 80-530 85 86
Email: europe.support@nsc.com
Deutsch Tel: +49 (0) 1 80-530 85 85
English Tel: +49 (0) 1 80 532 78 32

National Semiconductor Asia Pacific Customer Response Group
Tel: 65-2544466
Fax: 65-2504466
Email: sea.support@nsc.com

National Semiconductor Japan Ltd.
Tel: 81-3-5639-7560
Fax: 81-3-5639-7507

www.national.com

National does not assume any responsibility for any circuitry described, no circuit patent licenses are implied and National reserves the right at any time without notice to change said circuitry and specifications.